

*The Lightness of the Future*

# Trajnostni vidiki pri razvoju in proizvodni materiala za embalažo

Dr. Stanislav Kores

Okoljski dan gospodarstva  
Ljubljana, 4. junij 2019

TALUM

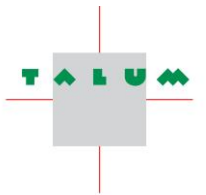

*The Lightness of the Future*

2018





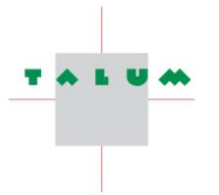

Lahkota prihodnosti

## Rastoči trg aluminija

### No1

Aluminij je kovina z najvišjo napovedano rastjo porabe v naslednjem desetletju.

### 75%

vsega proizvedenega aluminija je še vedno v uporabi.

### Embalaža

Zaradi higienskih lastnosti, toplotne prevodnosti in moči je aluminij **odlična rešitev za pakiranje**. Pri uporabi aluminijeve embalaže prihranimo več virov energije, kot jih porabimo.

### 50%

Napovedi kažejo, da se bo delež aluminija v avtomobilih do leta 2025 povečal za 50 %.



Z recikliranjem se prihrani **95% energije**, ki bi se porabila za pridelovanje primarnega aluminija.

### Transport



Aluminij sestavlja več kot **80%** teže majhnih in srednje velikih letal.



Več kot **1000 visoko hitrostnih ladij** ima ogrodje narejeno iz aluminija.



Uporaba aluminija v vlakih in metrojih ter tramvajih je razširjena po celotni Evropi.

### 7%

Letna rast porabe aluminija znaša kar sedem odstotkov.



Aluminij lahko **recikliramo v celoti**, brez da bi ogrozili kakovost materiala.

### Avtomobili

S pomočjo uporabe aluminija bi lahko težo določenih delov avtomobila **zmanjšali do 40%**.



Do leta 2020 naj bi povprečni avtomobil bil sestavljen iz kar **180 kg aluminija**.

### x2

Poraba aluminija v Evropi se naj bi v naslednjih 40 letih podvojila.



Letno se reciklira več kot **4 milijone ton** aluminija.

**Pralni in sušilni stroji:** učinkovito je zmanjšal njihovo težo.  
**Sodobni hladilniki:** omogoča znižanje cene in odlično toplotno prevodnost.  
**Računalništvo:** učinkovito izboljšuje možnost recikliranja produktov.

Potrošniške dobrine

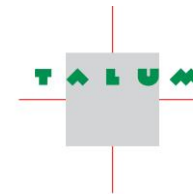

*The Lightness of the Future*

## Trajnostni razvoj



- Vse tri komponente trajnosti enako pomembne.
- Ne sme se favorizirati samo ene komponente.
- Cilj je doseči optimum vseh treh komponent.

## Vrednostna veriga aluminija

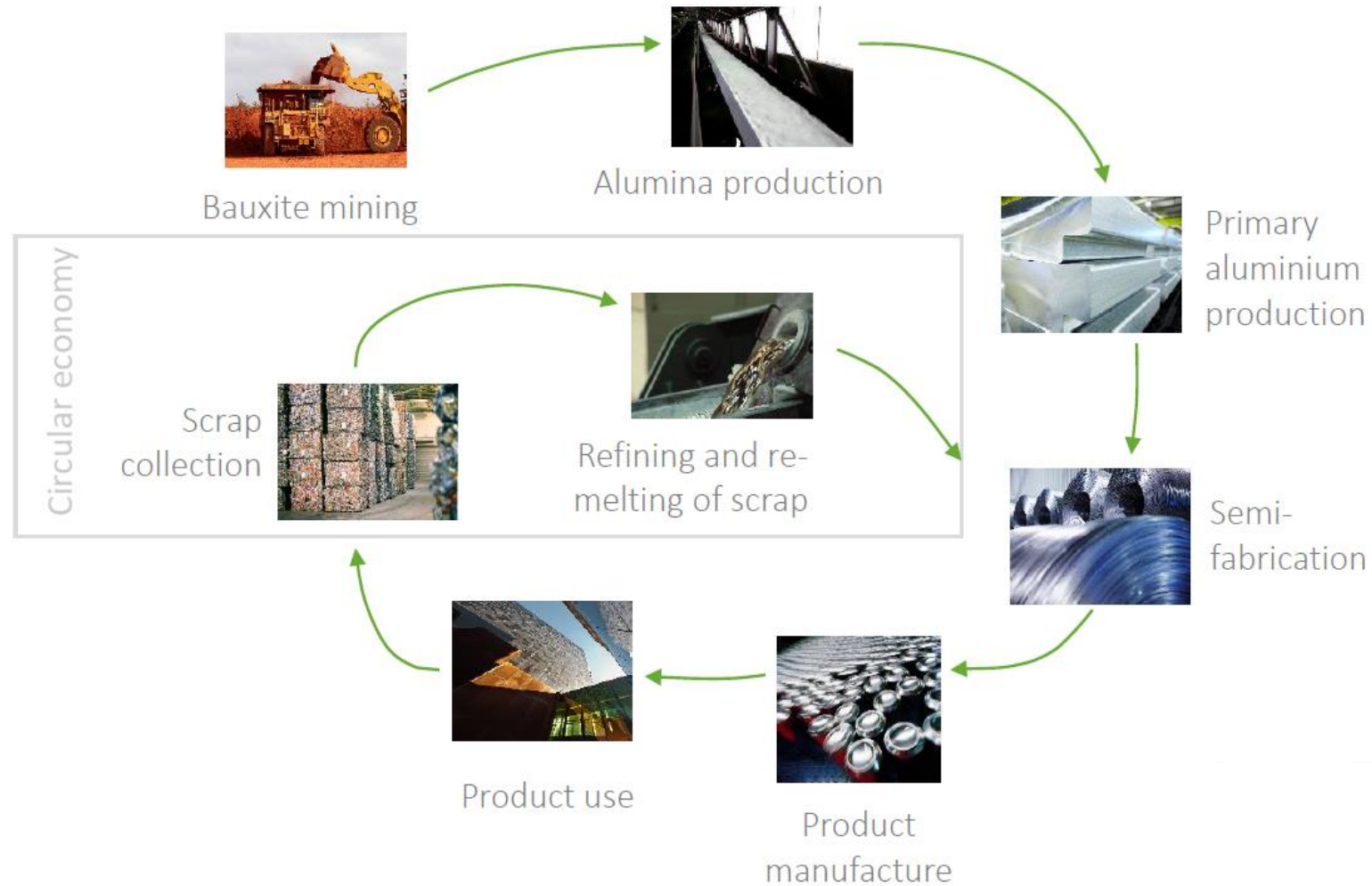

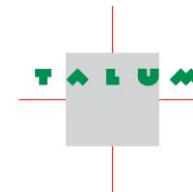

The Lightness of the Future

## Življenjska doba aluminijastih produktov

V prihodnjih letih bo se v odvisnosti od življenjske cikle produkta povečala količina aluminijevega odpada.

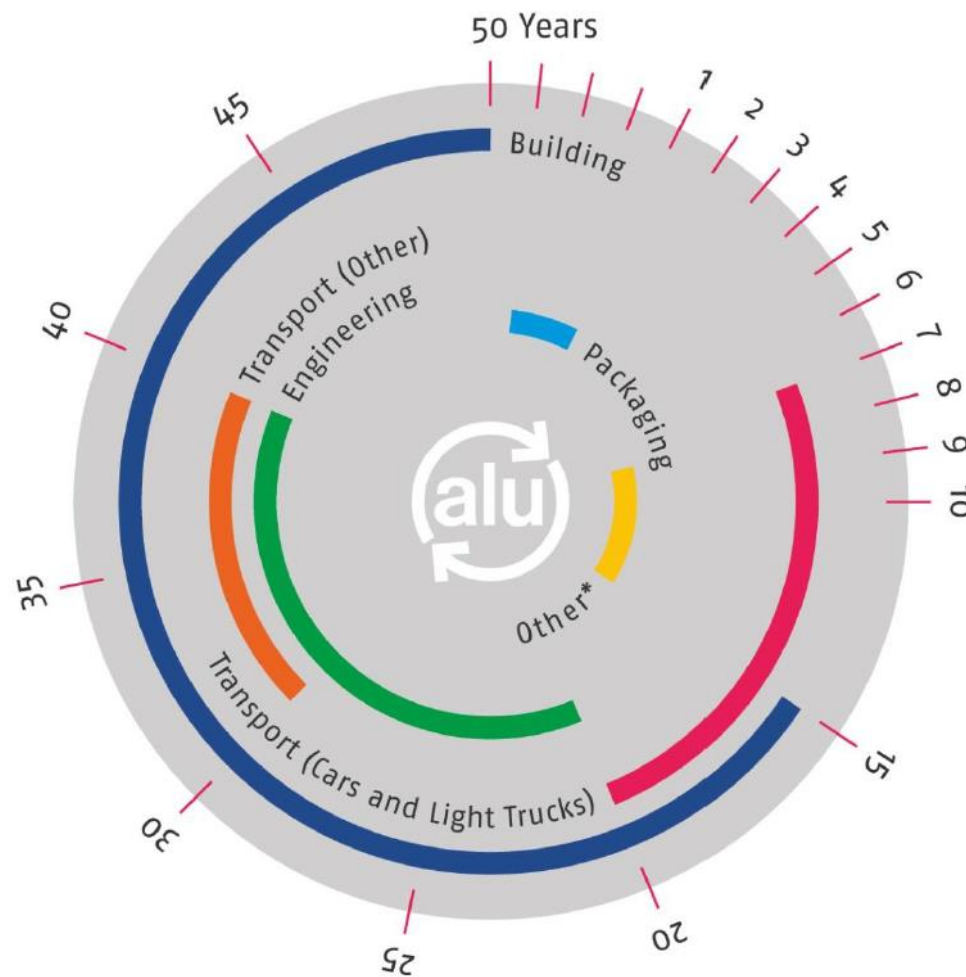

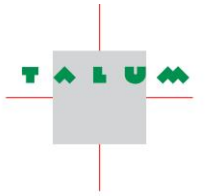

The Lightness of the Future

## Materiali za aerosol doze

Aerosol Cans – Material Split (2016)

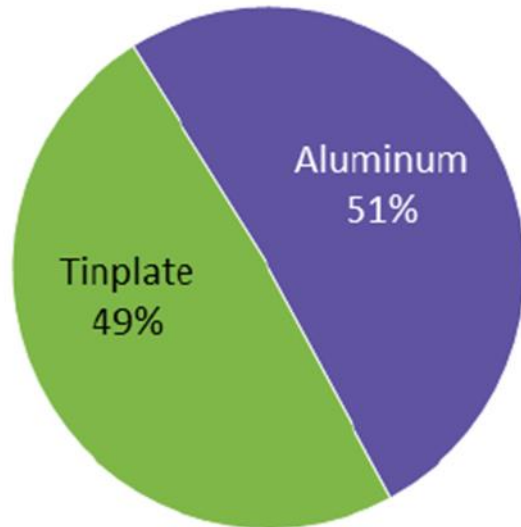

Sources: FEA, Aerobal, CSPA

Carbon emission <small>in kg CO<sub>2</sub>e/bottle</small>		
Material	Recycled	Virgin
Aluminum	0.19	1.29
Tinplate	0.05	0.27
PET	0.3	0.5

Source: DEFRA



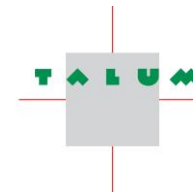

The Lightness of the Future

## Globalni trg aerosol doz

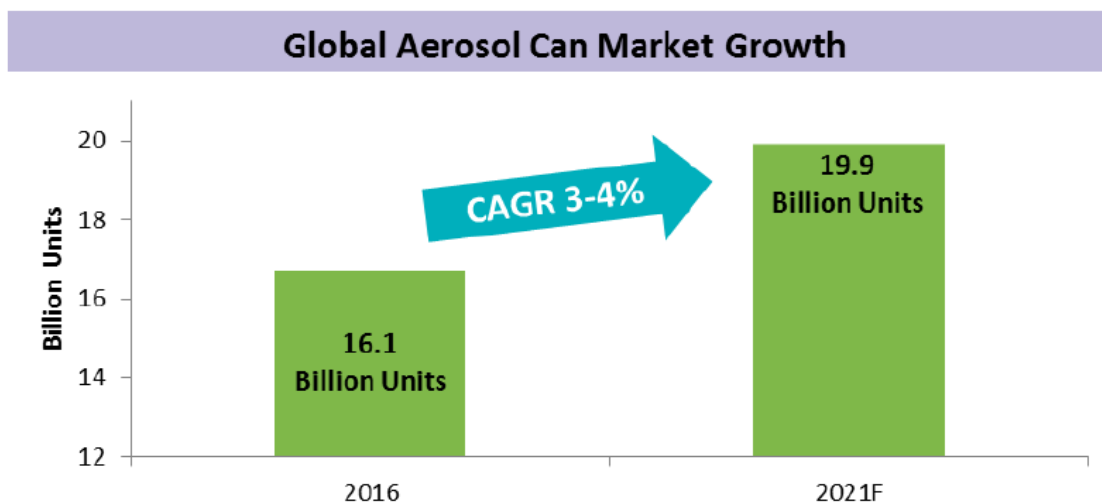

Company	Sustainability goals
Reckitt Benckiser	One third reduction in CO2 emission by 2020 per product
Unilever	Halving the environment impact in the products by 2030
Beiersdorf	Reducing CO2 emissions by 30% in 2020 per product sold
Henkel	30% less CO2 per ton by 2020
P&G	Reduce absolute GHG emissions by 30% by 2020

## Največji proizvajalec rondelic v EU



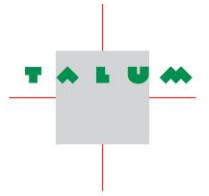

*The Lightness of the Future*

## Proizvodni proces izdelave aluminijastih rondelic

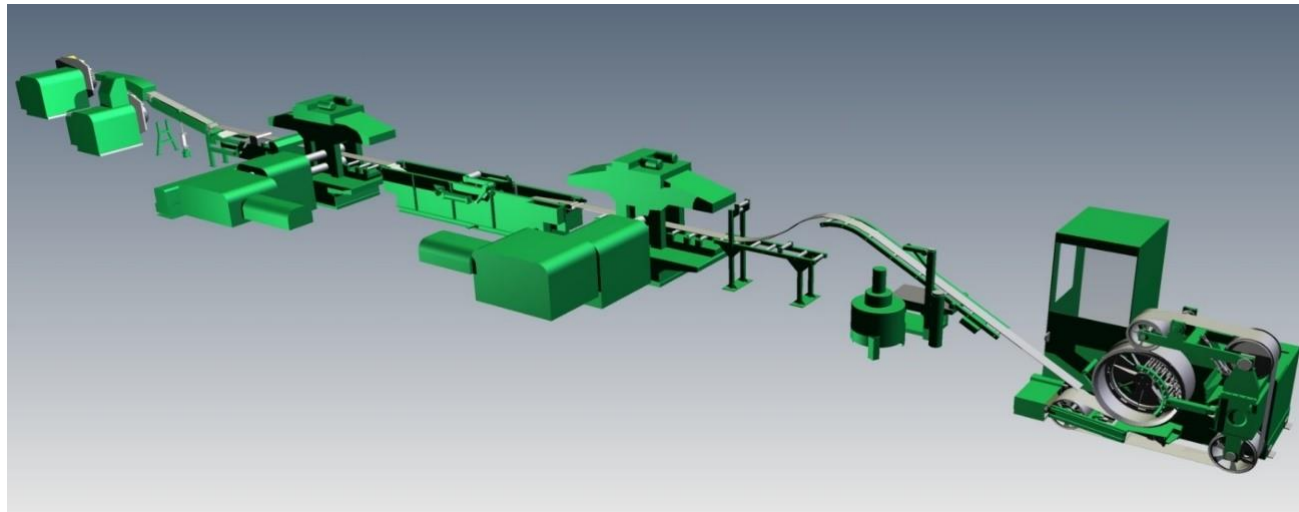

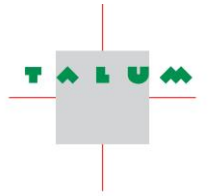

The Lightness of the Future

## Proizvodni proces izdelave aerosol doz



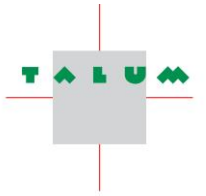

*The Lightness of the Future*

## Trajnosti izzivi pri proizvodnji aerosol doz

### Sustainability Challenges

Product Complexity

Difficulty in implementing changes in the product design

Suppliers not keen on product development

Smaller suppliers in developing markets focus on product availability

High carbon footprint of raw materials

Absence of integrated approach in product development

*Source: Beroe Analysis*

**Light weight aerosol cans**

Light weighting has been a popular trend and has helped in significantly reducing the weight of the packaging over the years resulting in savings in material costs as well as reducing the carbon footprint

**Use of Compressed Air as a propellant**

New valve designs and spray technology developed by Airopack, Salvalco, etc., would help eliminate the use of harmful propellants and enable the use of compressed air such as nitrogen and carbon dioxide as propellants

**Innovation in product formulation**

Developments in product formulation with the use of polymers in hair sprays has helped to cut down the amount of propellants by up to 55% and there by achieving significant carbon savings

**Increased recycled content**

Aluminum aerosol cans predominantly uses virgin metal, Ball had developed an alloy which uses about 25% recycled content and is 15% lighter helping to cut carbon footprint by 20% per can

**Compressed Aerosol Cans**

Compressed aerosol cans use 50% less propellant and 25% less aluminum, also more cans could be transported at one time resulting in significant carbon emission savings



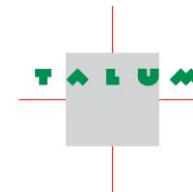

The Lightness of the Future

## Aluminijeve zlitine za izdelavo aerosol doz

Zlitina	Preoblikovanje	Površina	Mehanske lastnosti	Mehanske lastnosti po polimerizaciji	Deformabilni in razpočni tlak	Oblikovanje	Potencial za prihranek na materialu (debelina stene)
Al 99.5%	😊	😊	😐	😞	😐	😊	😞
Al 99.7%	😊	😊	😐	😞	😐	😊	😞
AlMn0.3	😊	😊	😊	😊	😊	😊	😊
AlMn0.4	😊	😊	😊	😊	😊	😊	😊
AlMn0.6	😊	😊	😊😊	😊	😊😊	😊	😊
T 1, T2	😊	😊😊	😊😊	😊	😊😊	😊	😊
AlMnMg	😊	😊	😊😊	😊	😊😊	😊	😊😊

## Trajnostni proces

### Krožno gospodarjenje z našimi partnerji

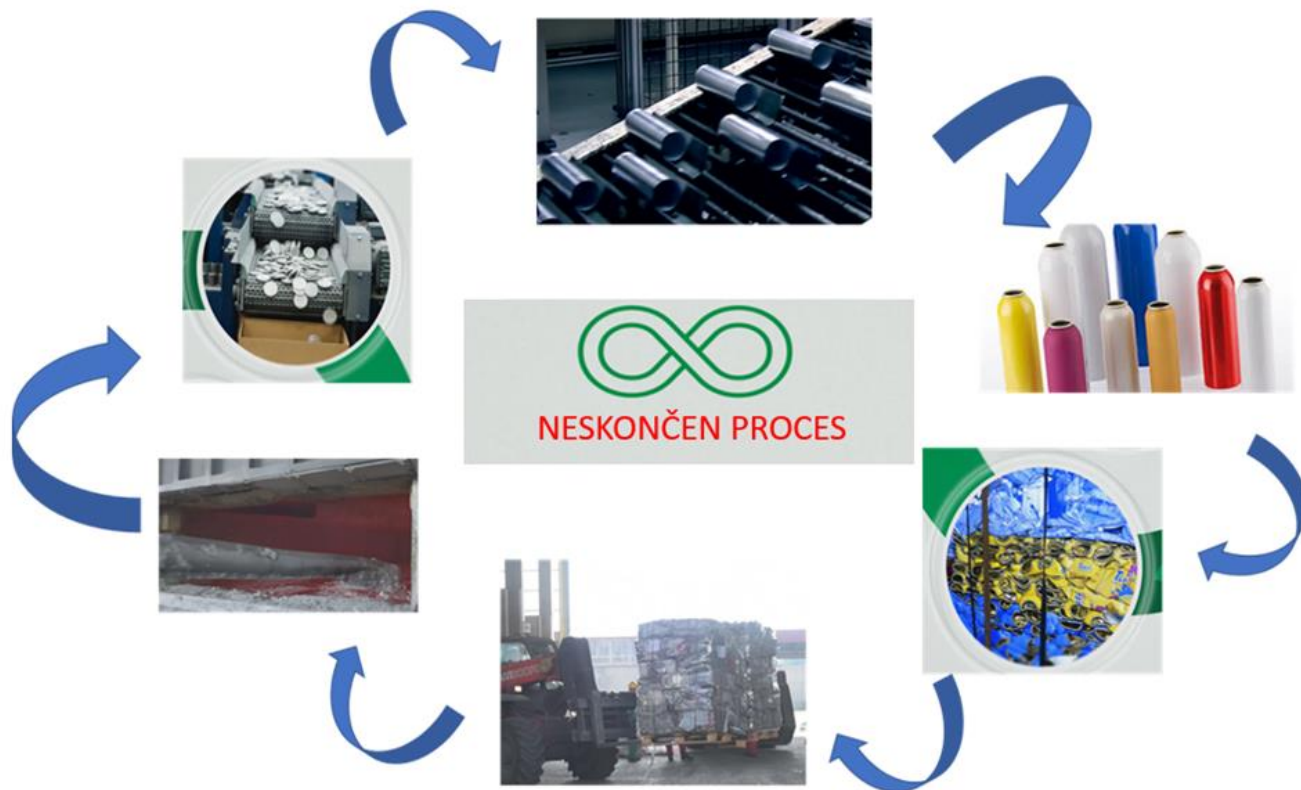





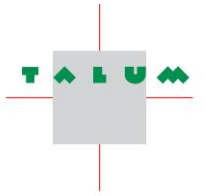

*The Lightness of the Future*

# (P)ostanite trajnostni!